

4

3

2

1

### REVISION

ZONE	LTR	ECN	DESCRIPTION	DATE	APPROVED
	A	35662	NEW RELEASE	5/1/95	[Signature]
	B	41973	UPDATE REV. LETTER	10/11/95	[Signature]
	C		UPDATE PER ECO-10-017486	8/25/10	PJS

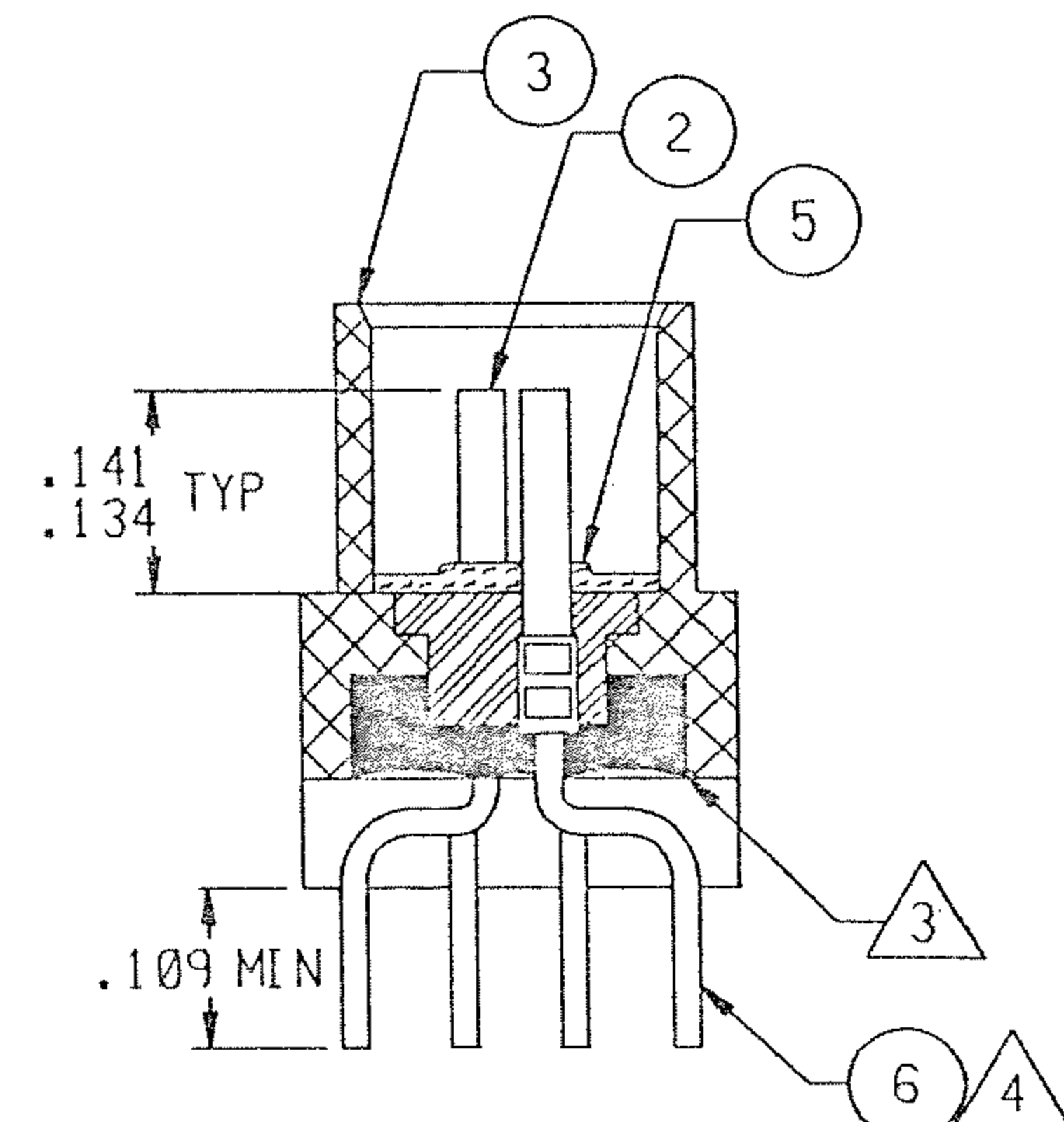
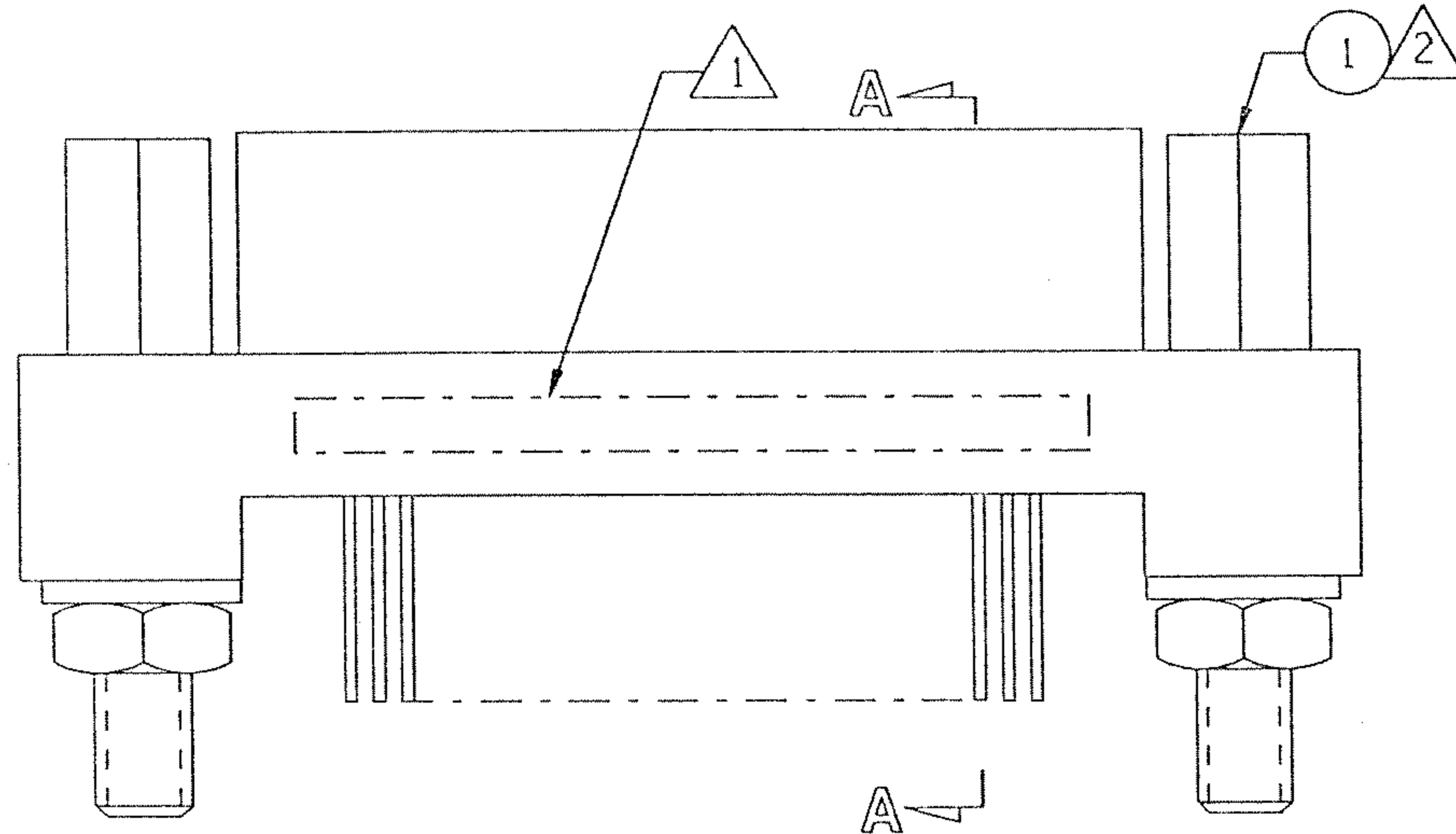
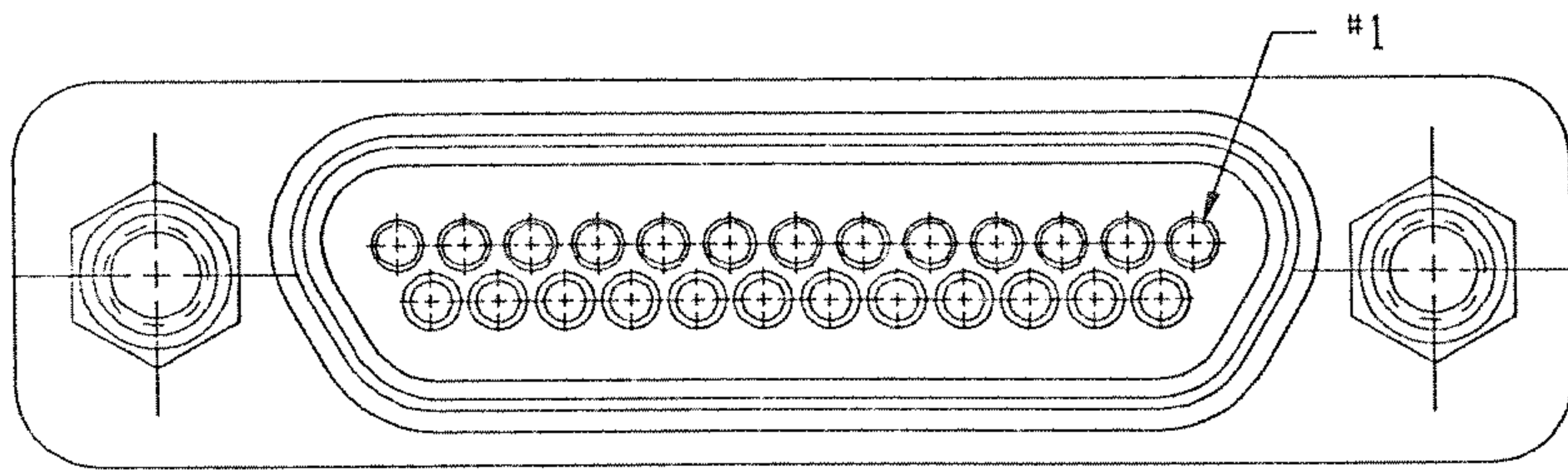

SECTION A - A

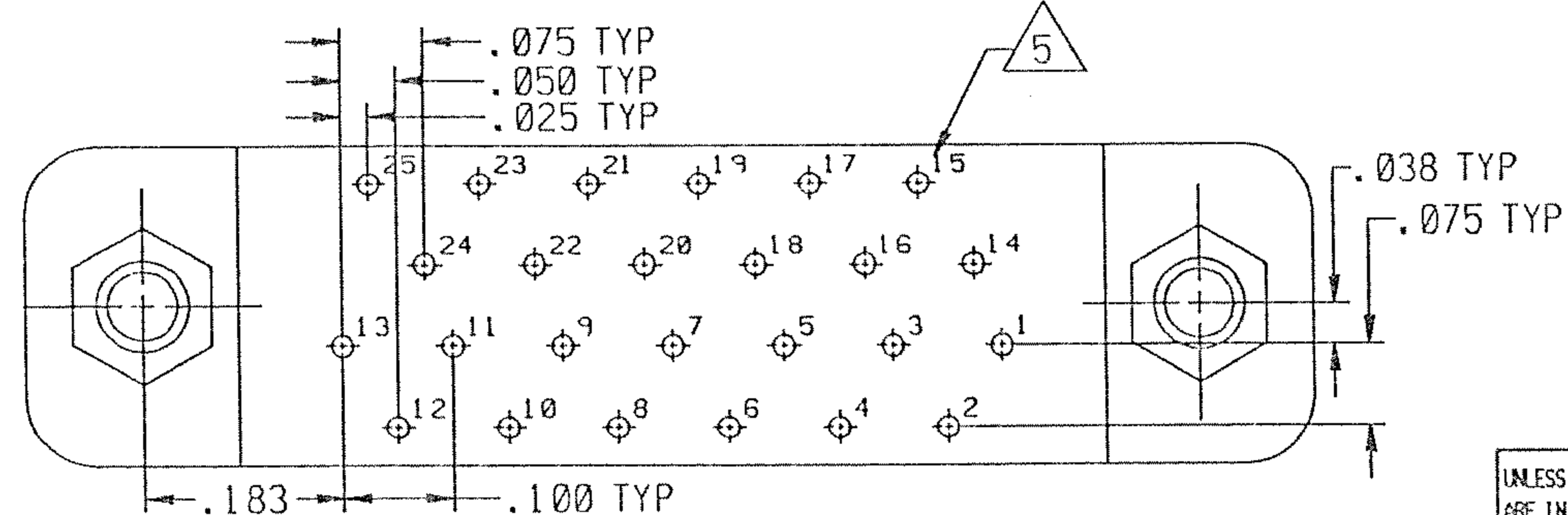

#### NOTES: UNLESS OTHERWISE SPECIFIED

- ① MARK PER TPD.
- ② ITEM 1 (JACKNUT ASSEMBLY, 2 PLCS) TO BE MOUNTED ONTO THE CONNECTOR.
- ③ EPOXY AS SHOWN. WICKING PERMITTED BEYOND POTTING WELL.
- ④ TERMINAL WIRES TO BE SOLDER DIPPED UP TO THE MOUNTING SURFACE MINIMUM.
- ⑤ LEAD IDENTIFICATION AS SHOWN ARE FOR REFERENCE ONLY. DO NOT ACTUALLY APPEAR ON THE PART.
- ⑥ CRIMP LEADS INTO CONTACTS PER MEP 302-05.

UNLESS OTHERWISE SPECIFIED DIMENSIONS ARE IN INCHES. TOLERANCE ARE: FRACTIONS ± 1/8 DECIMALS .XX ± .01 XXX ± .005 ANGLES ± 2°	APPROVALS		 <b>MICRODOT CONNECTORS</b> A DIVISION OF UNI-STAR INDUSTRIES INC. 306 PASADENA AVE., SO. PASADENA, CA 91030	PROD CODE 845 CODE M
	SIGNATURE	DATE		
MATERIAL:	DRAWN MEL F. CAMPOS	07/31/95	METAL SHELL 'D' CONNECTOR, RCPT MCK-**-P-25SST2 (180° WITHOUT TB BLOCK) 094-5406-7003	SIZE A 98278 CODE IDENT NO. 1-1532142-8 DRAWING NO.
FINISH:	CHECKED [Signature]	08/1/95		
	PRO. ENG. [Signature]			
	APPROVED			
	THIS DOCUMENT IS THE PROPERTY OF MICRODOT CONNECTORS, A DIVISION OF UNI-STAR INDUSTRIES INC. USE OF THIS DOCUMENT OR ANY PART THEREOF IS STRICTLY FORBIDDEN WITHOUT THE EXPRESS WRITTEN PERMISSION OF MICRODOT CONNECTORS, A DIVISION OF UNI-STAR INDUSTRIES INC.			